

THIS DRAWING IS UNPUBLISHED. RELEASED FOR PUBLICATION
 © COPYRIGHT BY TYCO ELECTRONICS CORPORATION. ALL RIGHTS RESERVED.

LOC	DIST	REVISIONS			
P	LTR	DESCRIPTION	DATE	DWN	APVD
G	86	M	REDRAWN PER 0G3A-0400-04	02JUN04	JR MS

- 1 TONGUE MATERIAL THICKNESS .045±.003
- △ 2 BODY: COPPER PER ASTM B-152
 TIN PER ASTM B-545
 INSULATION: PVC, COLOR - BLUE
 METALLIC SLEEVE: COPPER PER ASTM B-152
 METALLIC BAND: STEEL PER ASTM A109
- 3 FOR .377 MAX WIRE INSULATION DIA

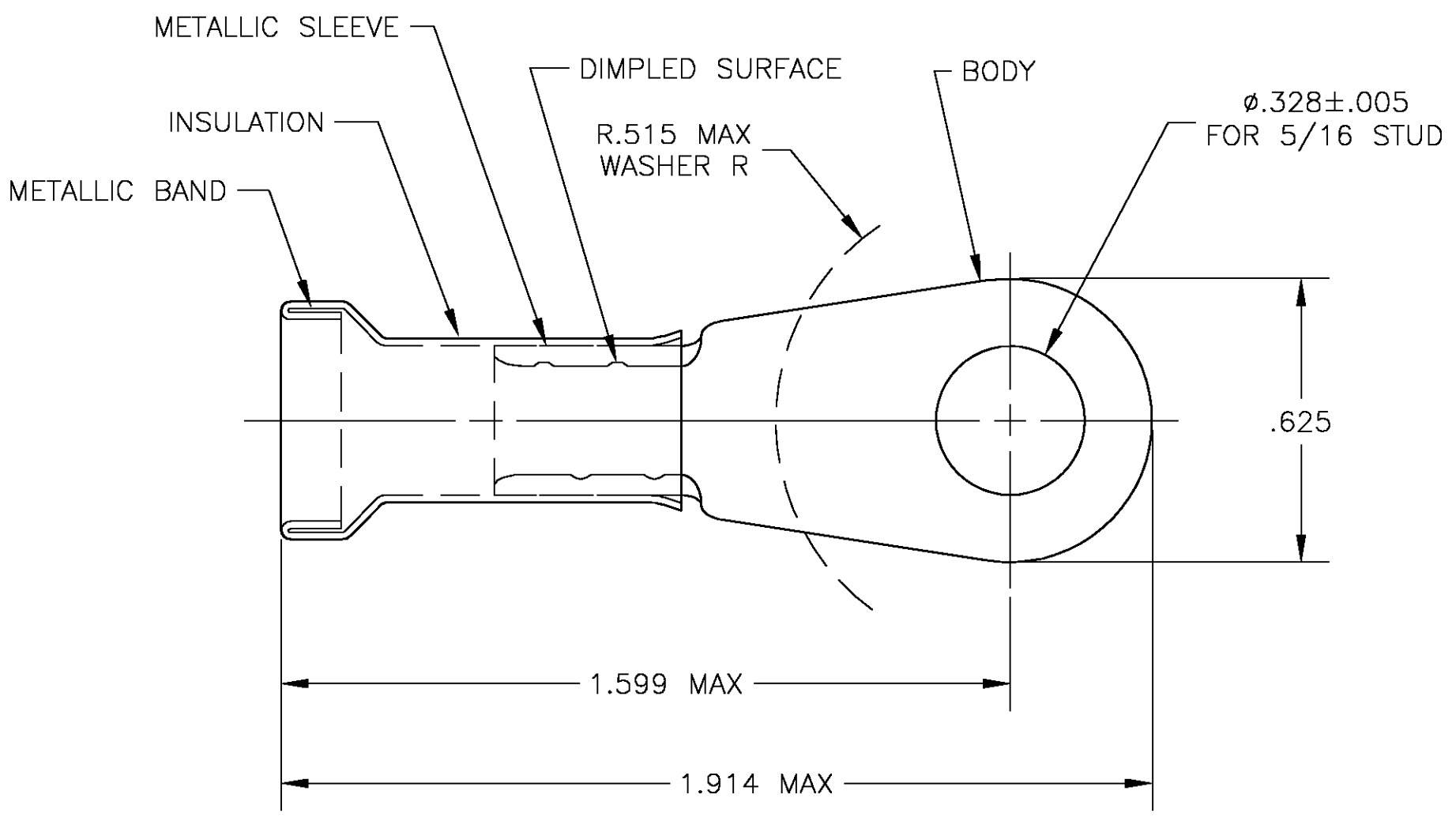

P/N ON TAPE	QTY	DESCRIPTION	PART NO
2-322006-3	20	LOOSE PIECE, BOX	8-322006-5
	1	WIRE TERMINAL	322006

THIS DRAWING IS A CONTROLLED DOCUMENT.		DWN jr_ruth 02JUN04	Tyco Electronics Corporation Harrisburg, PA 17105	
DIMENSIONS: INCHES		CHK MJ SPICER 02JUN04		
		APVD MJ SPICER 02JUN04	NAME TERMINAL, AMPLI-BOND, RING TONGUE WIRE SIZE: 6	
TOLERANCES UNLESS OTHERWISE SPECIFIED:		PRODUCT SPEC	RESTRICTED TO	
0 PLC ± -		APPLICATION SPEC	SIZE	CAGE CODE
1 PLC ± -		WEIGHT	A3	00779
2 PLC ± -		DRAWING NO		322006
3 PLC ± .008		CUSTOMER DRAWING		
4 PLC ± -		SCALE	3:1	SHEET 1 OF 1
ANGLES ± 5°		REV	M	
FINISH				
- △ 2				